



US 20150379925A1

(19) **United States**

(12) **Patent Application Publication**  
**Jung et al.**

(10) **Pub. No.: US 2015/0379925 A1**

(43) **Pub. Date: Dec. 31, 2015**

(54) **ORGANIC LIGHT EMITTING DISPLAY DEVICE**

**Publication Classification**

(71) Applicant: **Samsung Display Co., Ltd.**, Yongin-si (KR)

(51) **Int. Cl.**  
**G09G 3/32** (2006.01)

(72) Inventors: **Chan-Sung Jung**, Yongin-si (KR);  
**Jae-Won Choi**, Yongin-si (KR);  
**Tae-Hyeog Jung**, Yongin-si (KR)

(52) **U.S. Cl.**  
CPC ..... **G09G 3/3208** (2013.01); **G09G 2300/046** (2013.01)

(21) Appl. No.: **14/849,447**

(57) **ABSTRACT**

(22) Filed: **Sep. 9, 2015**

An organic light emitting display device includes a plurality of pixels, each of the plurality of pixels including: a first sub-pixel configured to emit light of a first color; a second sub-pixel configured to emit light of a second color that is different from the first color; a third sub-pixel configured to emit light of a third color that is different from the first and second colors; and a transmission sub-pixel configured to selectively transmit external light in response to an electrical signal.

**Related U.S. Application Data**

(63) Continuation of application No. 13/975,265, filed on Aug. 23, 2013, now Pat. No. 9,159,295.

**Foreign Application Priority Data**

(30) Feb. 12, 2013 (KR) ..... 10-2013-0014972

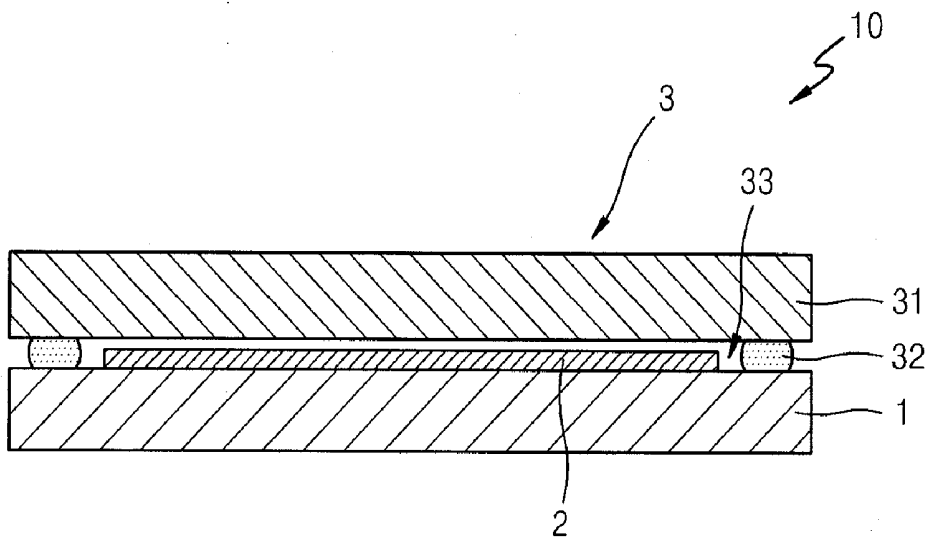

FIG. 1

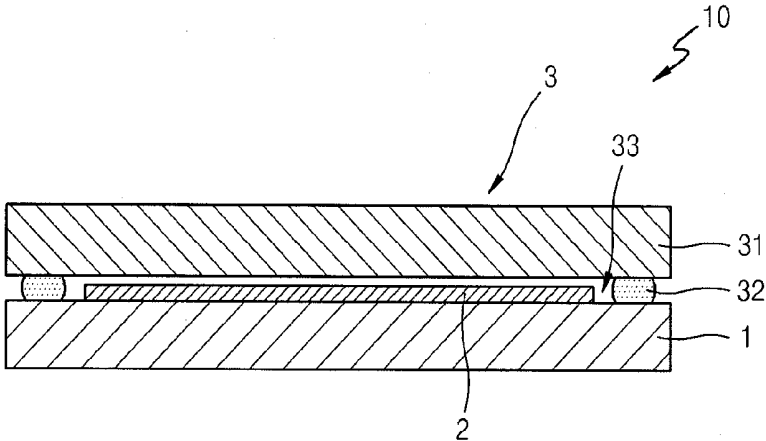

FIG. 2

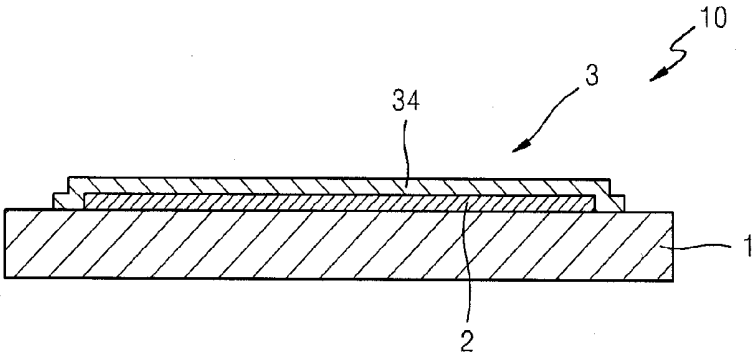

FIG. 3

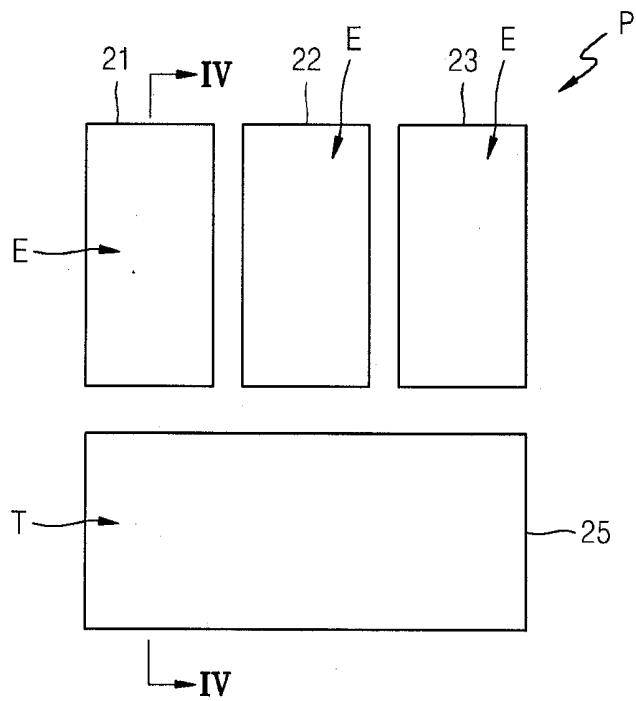

FIG. 4

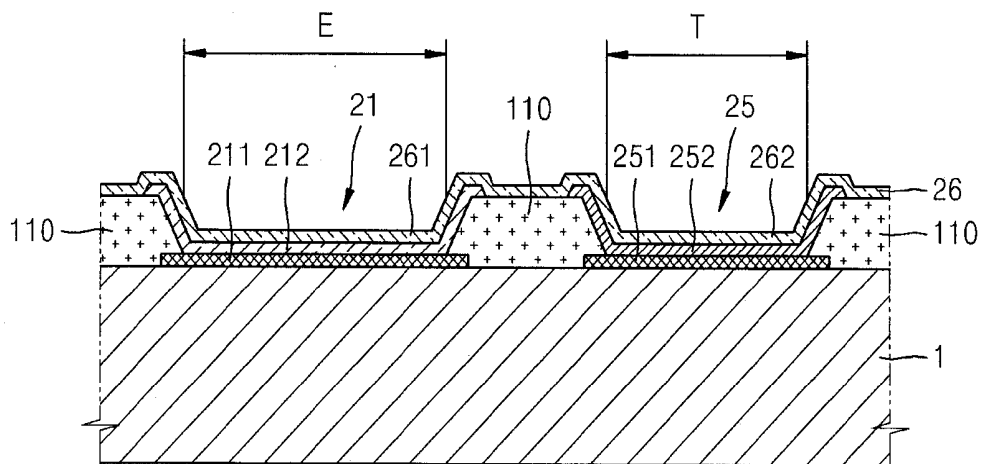

FIG. 5

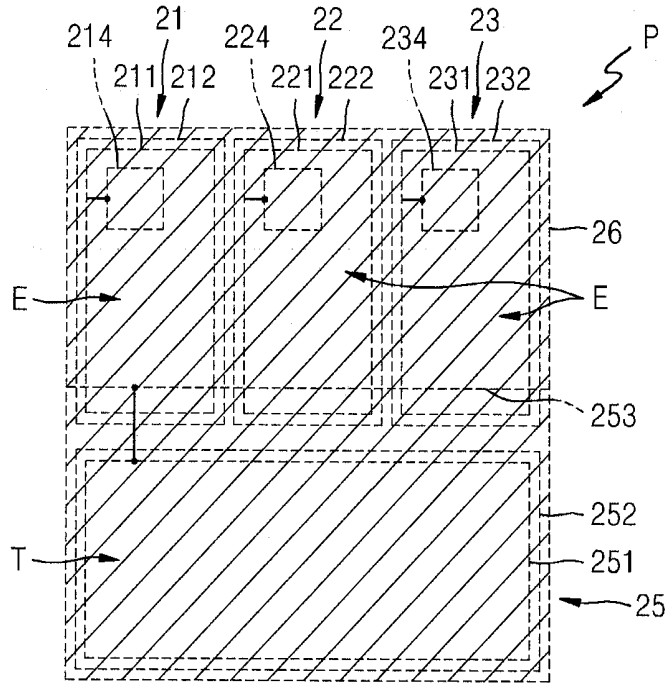

FIG. 6

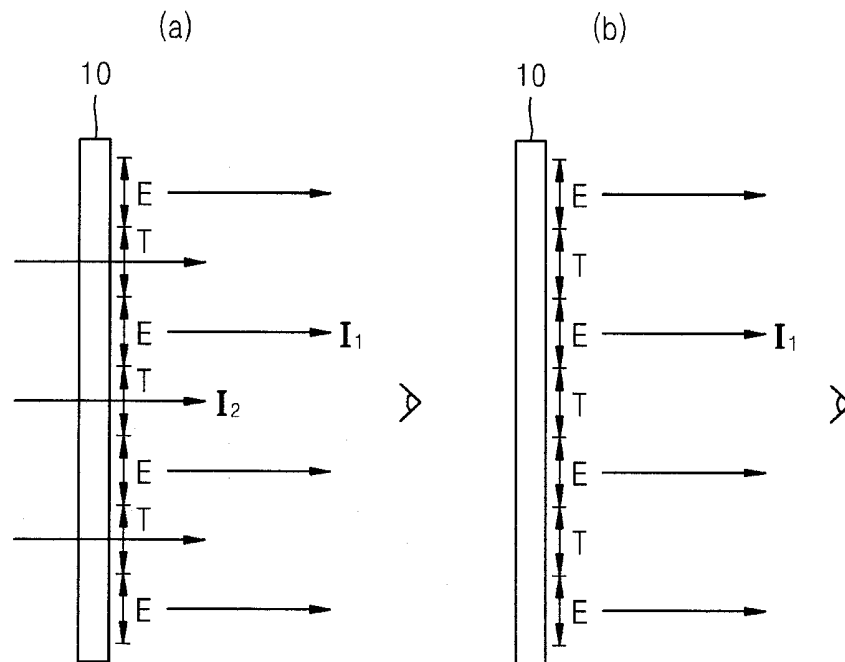

FIG. 7

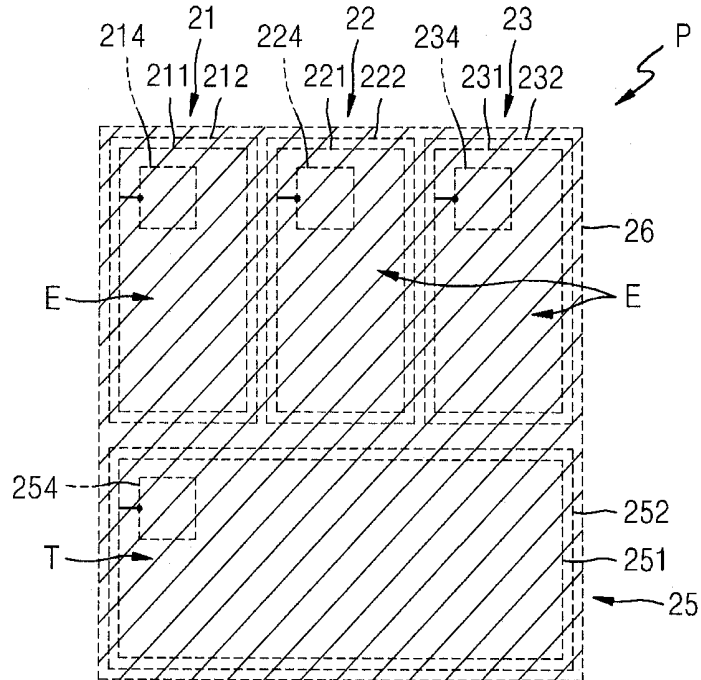

FIG. 8

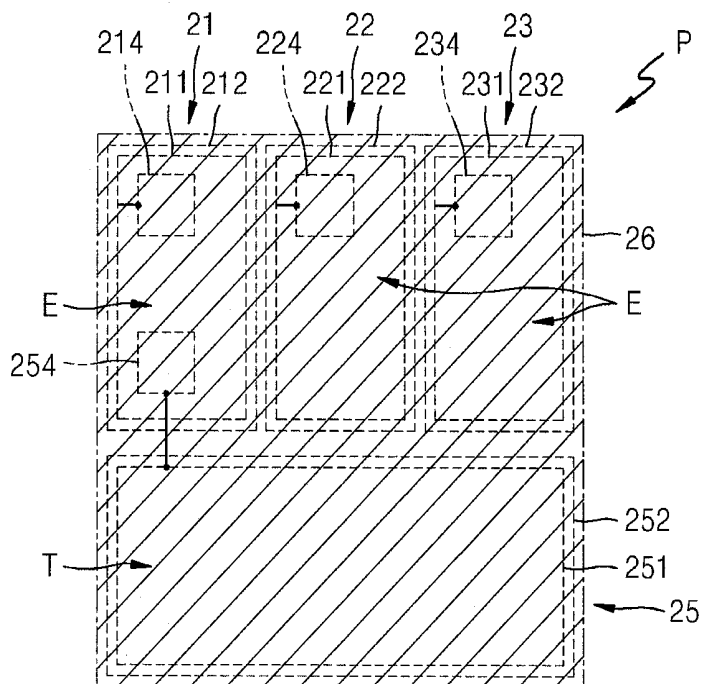

FIG. 9

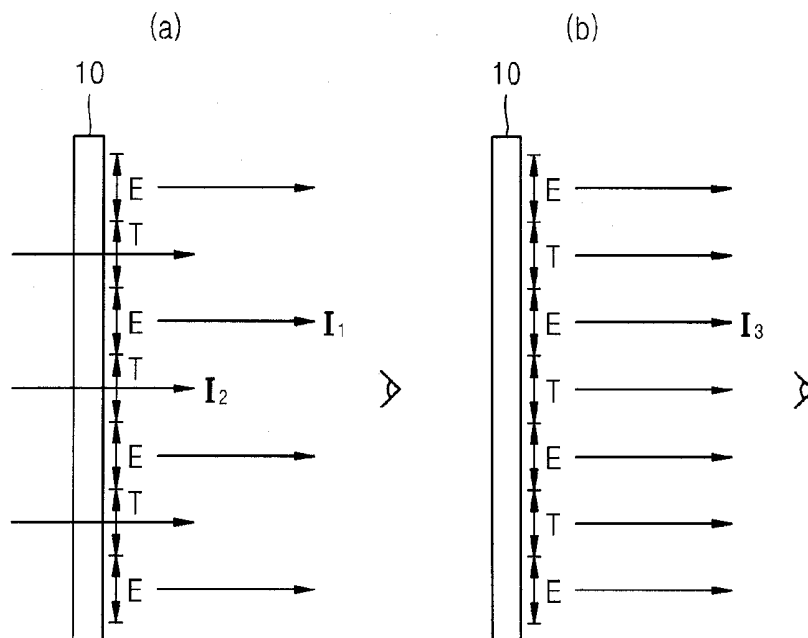

FIG. 10

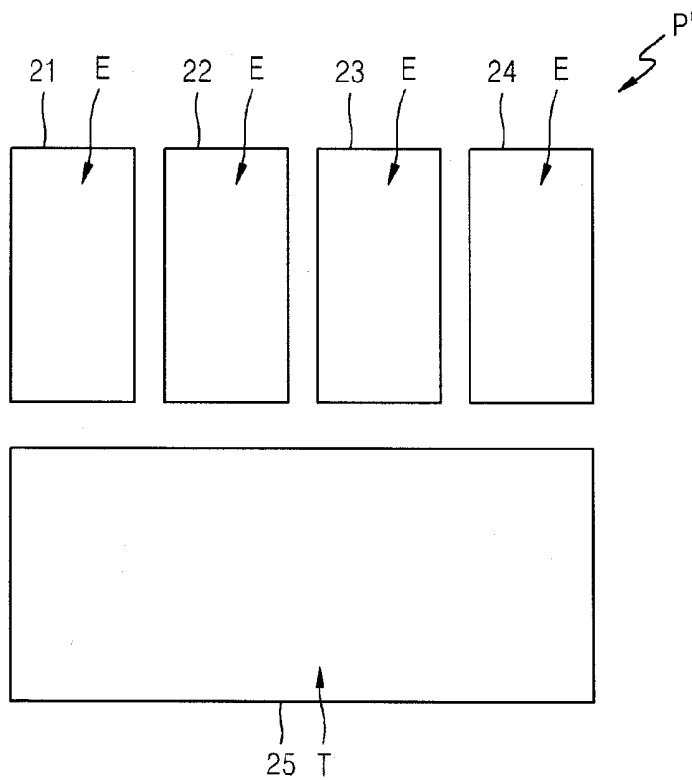
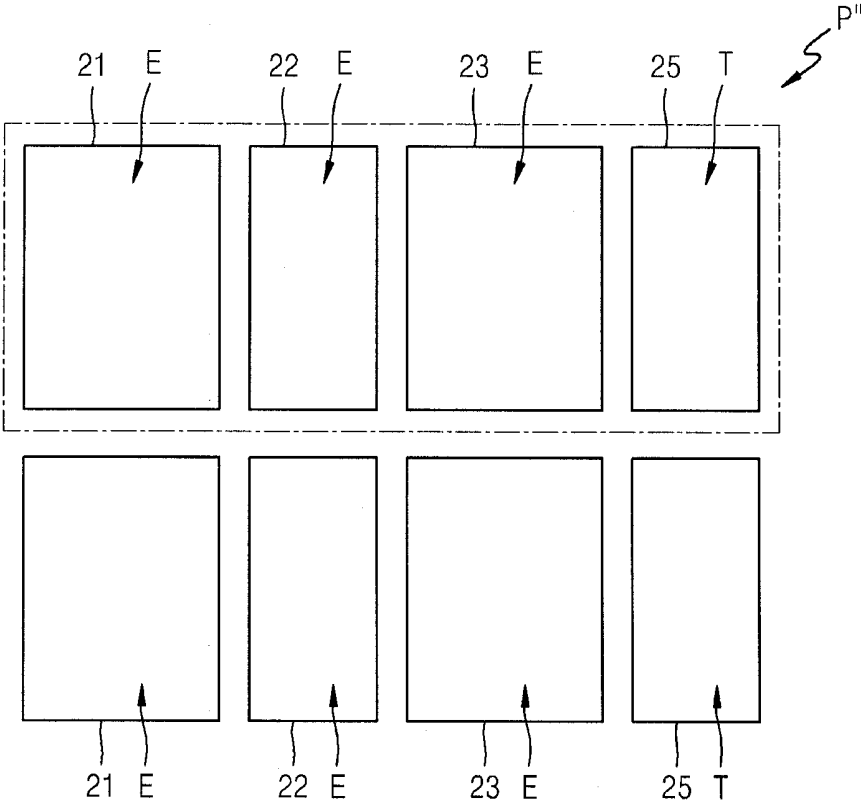

FIG. 11



## ORGANIC LIGHT EMITTING DISPLAY DEVICE

### CROSS-REFERENCE TO RELATED APPLICATION

[0001] This application is a continuation of U.S. patent application Ser. No. 13/975,265, filed Aug. 23, 2013, which claims priority to and the benefit of Korean Patent Application No. 10-2013-0014972, filed Feb. 12, 2013, the entire content of both of which is incorporated herein by reference.

### BACKGROUND

[0002] 1. Field

[0003] Embodiments of the present invention relate to an organic light emitting display device.

[0004] 2. Description of the Related Art

[0005] Organic light emitting display devices are being widely applied to personal portable devices such as MP3 players, mobile phones, and TVs due to their superior characteristics such as wide viewing angles, high contrast, fast response speed, and low power consumption. Such an organic light emitting display device has a self-emission property, and thus, an additional light source is not necessary, unlike a liquid crystal display (LCD) device, and therefore a thickness and a weight of the organic light emitting display device may be reduced. Also, an organic light emitting display device may be formed as a transparent display device by including transparent thin film transistors (TFTs) or organic light emitting diodes therein or by forming a transmission region (or transmission window) that is separate from pixel regions.

[0006] However, such a transparent organic light emitting display device has a fixed transmittance so as not to meet the demand of a user who wants to adjust a transmittance of the organic light emitting display device.

### SUMMARY

[0007] Embodiments of the present invention provide an organic light emitting display device capable of adjusting a transmittance thereof.

[0008] According to an aspect of the present invention, there is provided an organic light emitting display device including a plurality of pixels, each of the plurality of pixels including: a first sub-pixel configured to emit light of a first color; a second sub-pixel configured to emit light of a second color that is different from the first color; a third sub-pixel configured to emit light of a third color that is different from the first and second colors; and a transmission sub-pixel configured to selectively transmit external light in response to an electrical signal.

[0009] The first, second, and third sub-pixels may respectively include a first sub-pixel electrode, a second sub-pixel electrode, and a third sub-pixel electrode that are separate from each other, and the transmission sub-pixel includes a transmission sub-pixel electrode that is separate from the first, second, and third sub-pixel electrodes.

[0010] The organic light emitting display device may further include: a first driving circuit, a second driving circuit, and a third driving circuit that are electrically coupled to the first, second, and third sub-pixel electrodes, respectively; and a switching line electrically coupled to the transmission sub-pixel electrode.

[0011] The organic light emitting display device may further include: a first driving circuit, a second driving circuit,

and a third driving circuit that are electrically coupled to the first, second, and third sub-pixel electrodes, respectively; and a transmission driving circuit electrically coupled to the transmission sub-pixel electrode.

[0012] The transmission driving circuit may be at the transmission sub-pixel.

[0013] The transmission driving circuit may be at one of the first, second, and third sub-pixels adjacent the transmission sub-pixel.

[0014] The organic light emitting display device may further include an opposite electrode at each of the plurality of pixels and facing the first, second, and third sub-pixel electrodes and the transmission sub-pixel electrode.

[0015] The transmission sub-pixel may be configured to transmit the external light when the electrical signal is not applied, and to block transmission of the external light when the electrical signal is applied.

[0016] The transmission sub-pixel may be configured to transmit the external light when the electrical signal is not applied, and to emit light of one of the first, second, and third colors when the electrical signal is applied.

[0017] The transmission sub-pixel may be configured to transmit the external light when the electrical signal is not applied, and to emit light of a fourth color that is different from the first, second, and third colors when the electrical signal is applied.

[0018] Each of the pixels may further include a fourth sub-pixel that is configured to emit light of a fourth color that is different from the first, second, and third colors.

[0019] According to another aspect of the present invention, there is provided an organic light emitting display device including a plurality of pixels, each of the plurality of pixels including: an emission sub-pixel configured to display an emission image; and a transmission sub-pixel configured to selectively display a transmission image by external light transmitted through the transmission sub-pixel.

[0020] The emission sub-pixel may include an emission sub-pixel electrode, and the transmission sub-pixel may include a transmission sub-pixel electrode.

[0021] The organic light emitting display device may further include: an emission driving circuit electrically coupled to the emission sub-pixel electrode; and a switching line electrically coupled to the transmission sub-pixel electrode.

[0022] The organic light emitting display device may further include: an emission driving circuit electrically coupled to the emission sub-pixel electrode; and a transmission driving circuit electrically coupled to the transmission sub-pixel electrode.

[0023] The transmission driving circuit may be at the transmission sub-pixel.

[0024] The transmission driving circuit may be at the emission sub-pixel adjacent to the transmission sub-pixel.

[0025] The organic light emitting display device may further include an opposite electrode at each of the plurality of pixels and facing the emission sub-pixel electrode and the transmission sub-pixel electrode.

[0026] The transmission sub-pixel may be configured to display the transmission image when an electrical signal is not applied and not to display the transmission image when the electrical signal is applied.

[0027] The transmission sub-pixel may be configured to display the transmission image when an electrical signal is not applied and to display the emission image when the electrical signal is applied.

## BRIEF DESCRIPTION OF THE DRAWINGS

[0028] The above and other features and aspects of the present invention will become more apparent by describing in detail exemplary embodiments thereof with reference to the attached drawings in which:

[0029] FIG. 1 is a cross-sectional view of an organic light emitting display device according to an embodiment of the present invention;

[0030] FIG. 2 is a cross-sectional view of an organic light emitting display device according to another embodiment of the present invention;

[0031] FIG. 3 is a plan view of a pixel in the organic emission unit shown in FIG. 1 and FIG. 2;

[0032] FIG. 4 is a cross-sectional view of the pixel taken along the line IV-IV of FIG. 3;

[0033] FIG. 5 is a plan view of the pixel of FIG. 3 in more detail;

[0034] FIG. 6 is a diagram schematically showing operations of an organic light emitting display device including the pixel shown in FIG. 5;

[0035] FIG. 7 is a plan view showing another example of the pixel shown in FIG. 3;

[0036] FIG. 8 is a plan view showing another example of the pixel shown in FIG. 3;

[0037] FIG. 9 is a diagram schematically showing operations of an organic light emitting display device including the pixel of FIG. 8;

[0038] FIG. 10 is a plan view showing a pixel in another example of the organic emission unit shown in FIG. 1 and FIG. 2; and

[0039] FIG. 11 is a plan view showing a pixel in another example of the organic emission unit shown in FIG. 1 and FIG. 2.

## DETAILED DESCRIPTION

[0040] Hereinafter, embodiments of the present invention will be described in detail below with reference to accompanying drawings. As used herein, the term “and/or” includes any and all combinations of one or more of the associated listed items. Expressions such as “at least one of,” when preceding a list of elements, modify the entire list of elements and do not modify the individual elements of the list.

[0041] FIGS. 1 and 2 are cross-sectional views of organic light emitting display devices according to different embodiments of the present invention.

[0042] Referring to FIG. 1, the organic light emitting display device 10 of the present embodiment includes an organic emission unit 2 formed on a surface of a substrate 1, and a sealing unit 3 for sealing the organic emission unit 2.

[0043] According to the embodiment shown in FIG. 1, the sealing unit 3 may include a sealing substrate 31. The sealing substrate 31 may be formed of a transparent glass substrate or a transparent plastic substrate so as to display images from the organic emission unit 2. The sealing substrate 31 may also reduce (or prevent) external air and moisture from infiltrating into the organic emission unit 2.

[0044] Edges of the substrate 1 and the sealing substrate 31 are coupled to each other by a sealing material (or sealant) 32 so that a space 33 between the substrate 1 and the sealing substrate 31 may be sealed. Moisture absorbent or a filling material may be located in the space 33.

[0045] Instead of using the sealing substrate 31, as shown in FIG. 2, a thin sealing film 34 may be formed on the organic

emission unit 2 to protect the organic emission unit 2 from external air. The sealing film 34 may have a structure in which a layer formed of an inorganic material such as silicon oxide (e.g., SiO<sub>2</sub>) or silicon nitride (e.g., Si<sub>3</sub>N<sub>4</sub>) and a layer formed of an organic material such as epoxy or polyimide are alternately formed. However, embodiments of the present invention are not limited thereto, and a sealing structure formed of a transparent thin film may be used as the sealing film 34.

[0046] The organic light emitting display devices according to the embodiments shown in FIGS. 1 and 2 may be realized as a bottom emission type that displays images toward the substrate 1, a top emission type that displays images toward the sealing substrate 31 or the sealing film 34, or a dual-emission type that displays images toward both the substrate 1 and the sealing substrate 31 or toward both the substrate 1 and the sealing film 34.

[0047] Such an organic light emitting display device 10 may include a light emission region and a light transmission region so as to realize a transparent and/or see-through display device.

[0048] The organic emission unit 2 shown in FIG. 1 or FIG. 2 includes a plurality of pixels for displaying images. FIG. 3 is a plan view of a pixel P in the organic emission unit 2 shown in FIG. 1 and/or FIG. 2.

[0049] Each of the pixels includes emitting sub-pixels E for realizing light emission images, and a transmission sub-pixel 25 forming a transmission region T so as to transmit external light to form a transmission image.

[0050] The emission sub-pixels E may include a first sub-pixel 21, a second sub-pixel 22, and a third sub-pixel 23. The first sub-pixel 21 emits light of a first color, the second sub-pixel 22 emits light of a second color, and the third sub-pixel 23 emits light of a third color. The second color is different from the first color, and the third color is different from the first color and the second color. The first through third colors may be three different kinds of colors for realizing white light, for example, they may be red, green, and blue according to embodiments of the present invention.

[0051] The transmission sub-pixel 25 forming the transmission region T may be adjacent to the first through third sub-pixels 21, 22, and 23. In FIG. 3, one transmission sub-pixel 25 forms the transmission region T; however, embodiments of the present invention are not limited thereto, that is, a transmission sub-pixel adjacent to the first sub-pixel 21, another transmission sub-pixel adjacent to the second sub-pixel 22, and another transmission sub-pixel adjacent to the third sub-pixel 23 may be located independently (e.g., separated or spaced) from each other.

[0052] The transmission sub-pixel 25 is configured to selectively transmit external light (e.g., allows external light to pass through) according to application of an electric signal.

[0053] FIG. 4 is a cross-sectional view of the pixel taken along the line IV-IV of FIG. 3.

[0054] The first sub-pixel 21 includes a first sub-pixel electrode 211, a first emission layer 212 located on the first sub-pixel electrode 211, and an emission opposite electrode 261 located on the first emission layer 212.

[0055] The transmission sub-pixel 25 includes a transmission sub-pixel electrode 251, a transmission adjusting layer 252 located on the transmission sub-pixel electrode 251, and a transmission opposite electrode 262 located on the transmission adjusting layer 252. The transmission opposite electrode 262 may be electrically connected to the emission opposite electrode 261, for example, the transmission opposite

electrode **262** and the emission opposite electrode **261** may be coupled to each other to form one opposite electrode **26**.

[0056] The first sub-pixel electrode **211** and the transmission sub-pixel electrode **251** may be located on the substrate **1** independently (e.g., separately) from each other.

[0057] An insulating layer **110** is formed on the substrate **1** so as to cover edges of the first sub-pixel electrode **211** and the transmission sub-pixel electrode **251**, and the first sub-pixel electrode **211** and the transmission sub-pixel electrode **251** are exposed through openings (or gaps) of the insulating layer **110**.

[0058] The first emission layer **212** and the transmission adjusting layer **252** are formed on the exposed portions of the first sub-pixel electrode **211** and the transmission sub-pixel electrode **251**, and the opposite electrode **26** is formed on the first emission layer **212**, the transmission adjusting layer **252**, and the insulating layer **110**.

[0059] The substrate **1** may include driving circuit units (or driving circuits or drivers) that are electrically connected to the sub-pixel electrodes. Each of the driving circuit units may include at least a thin film transistor (TFT) and a capacitor.

[0060] FIG. 5 is a plan view of the pixel P shown in FIG. 3 in more detail.

[0061] The first sub-pixel **21**, the second sub-pixel **22**, and the third sub-pixel **23** respectively include the first sub-pixel electrode **211**, the second sub-pixel electrode **221**, and the third sub-pixel electrode **231**, which are independent from each other. In addition, the transmission sub-pixel **25** includes the transmission sub-pixel electrode **251** that is independent from the first sub-pixel electrode **211**, the second sub-pixel electrode **221**, and the third sub-pixel electrode **231**. The transmission sub-pixel electrode **251** may be disposed (or located) adjacent to all of the first, second, and third sub-pixel electrodes **211**, **221**, and **231** as shown in FIG. 5.

[0062] The first sub-pixel **21**, the second sub-pixel **22**, and the third sub-pixel **23** respectively include the first emission layer **212**, the second emission layer **222**, and the third emission layer **232** that respectively cover the first sub-pixel electrode **211**, the second sub-pixel electrode **221**, and the third sub-pixel electrode **231**. The transmission sub-pixel **25** includes the transmission adjusting layer **252** that covers the transmission sub-pixel electrode **251**.

[0063] The opposite electrode **26** is formed to cover all of the pixel P, for example, to cover the first, second, and third emission layers **212**, **222**, and **232**, and the transmission adjusting layer **252**. Although not shown in FIG. 5, the opposite electrode **26** may be formed to cover all of the pixels.

[0064] The first, second, and third sub-pixels **21**, **22**, and **23** may function as anodes, and the opposite electrode **26** may function as a cathode, or vice versa.

[0065] The first emission layer **212**, the second emission layer **222**, and the third emission layer **232** may be organic emission layers, and may respectively include an organic emission material emitting red light, an organic emission material emitting green light, and an organic emission material emitting blue light. Although not shown in FIG. 5, at least one or more organic layers including a hole injection transport layer and/or an electron injection transport layer may be further disposed (or located) between the first, second, and third sub-pixels **21**, **22**, and **23** and the opposite electrode **26**. When the first, second, and third sub-pixels **21**, **22**, and **23** are anode electrodes and the opposite electrode **26** is a cathode electrode, an organic layer including the hole injection transport layer for injecting and/or transporting the holes may be

disposed (or located) between the first, second, and third emission layers **212**, **222**, and **232** and the first, second, and third sub-pixels **21**, **22**, and **23**, and an organic layer including the electron injection transport layer for injecting and/or transporting the electrons may be disposed (or located) between the first, second, and third emission layers **212**, **222**, and **232**, and the opposite electrode **26**. The hole injection transport layer and the electron injection transport layer may be common layers that may be formed to cover all the pixels of the organic emission unit **2**.

[0066] The organic layers including the first emission layer **212**, the second emission layer **222**, and the third emission layer **232** may be formed in various ways, such as by vacuum deposition, printing, and/or laser thermal transfer methods.

[0067] The first sub-pixel electrode **211**, the second sub-pixel electrode **221**, and the third sub-pixel electrode **231** may be formed as transparent electrodes, semi-transparent electrodes, or reflective electrodes that may include indium tin oxide (ITO), indium zinc oxide (IZO), zinc oxide (ZnO), or indium (III) oxide (In<sub>2</sub>O<sub>3</sub>).

[0068] The opposite electrode **26** may be formed as a transparent electrode or a semi-transparent electrode including silver (Ag), magnesium (Mg), aluminum (Al), platinum (Pt), palladium (Pd), gold (Au), nickel (Ni), neodymium (Nd), iridium (Ir), chromium (Cr), lithium (Li), calcium (Ca), ytterbium (Yb), or a compound thereof. The opposite electrode **26** may be configured to transmit light by forming the compound as a thin film.

[0069] The first sub-pixel **21**, the second sub-pixel **22**, and the third sub-pixel **23** may respectively include a first driving circuit unit (or first driving circuit or first driver) **214**, a second driving circuit unit (or second driving circuit or second driver) **224**, and a third driving circuit unit (or third driving circuit or third driver) **234**. The first, second, and third driving circuit units **214**, **224**, and **234** may be electrically coupled to the first sub-pixel electrode **211**, the second sub-pixel electrode **221**, and the third sub-pixel electrode **231**, respectively. Each of the first, second, and third driving circuit units **214**, **224**, and **234** may include a thin film transistor and a capacitor. The first, second, and third driving circuit units **214**, **224**, and **234** may control light emission images from the first sub-pixel **21**, the second sub-pixel **22**, and the third sub-pixel **23**.

[0070] The transmission sub-pixel **25** may include a transmission sub-pixel electrode **251**, a transmission adjusting layer **252**, and a transmission opposite electrode **262** (refer to FIG. 3) that are sequentially stacked. The transmission sub-pixel **25** may transmit external light when an electric signal is not applied thereto, and may block the external light when an electric signal is applied thereto, or vice versa. To do this, the transmission sub-pixel **25** may include an electrochromic system.

[0071] The transmission sub-pixel electrode **251** may be formed of the same material as that of the first, second, and third sub-pixel electrodes **21**, **22**, and **23**. The transmission adjusting layer **252** may be formed by using an electrochromic material. The transmission opposite electrode **262** may be formed integrally with the emission opposite electrode **261** to form the opposite electrode **26**. However, embodiments of the present invention are not limited thereto; the transmission sub-pixel electrode **251** and the transmission opposite electrode **262** may be formed of an electrode material that is capable of adjusting a transmittance of the transmission adjusting layer **252**. Although not shown in the drawings, the

transmission sub-pixel **25** may further include a transmission opposite electrode patterned on the transmission sub-pixel **25** region.

**[0072]** As an example, the transmission sub-pixel electrode **251** and the transmission opposite electrode **262** may be formed of metal oxide, for example, nickel oxide (e.g., NiO) and tungsten oxide (e.g.,  $W_2O_3$ ), respectively. In addition, the transmission adjusting layer **252** disposed (or located) between the transmission sub-pixel electrode **251** and the transmission opposite electrode **262** may be formed of a transparent electrolyte. When a voltage is applied between the transmission sub-pixel electrode **251** and the transmission opposite electrode **262**, lithium ions leak out of the transmission sub-pixel electrode **251** that is formed of the nickel oxide and move to the transmission opposite electrode **262** formed of the tungsten oxide via the transmission adjusting layer **252**, and accordingly, external light transmission through the transmission sub-pixel **25** may be blocked. If a small amount of lithium is added when the transmission sub-pixel electrode **251** is formed, the color variation may occur faster in wider range.

**[0073]** As another example, the transmission sub-pixel electrode **251** may be formed of ITO and the transmission adjusting layer **252** may be formed of an organic/metal hybrid polymer including iron (Fe) ions. In addition, the opposite electrode **26** may be formed to cover the transmission adjusting layer **252**.

**[0074]** When an oxidation voltage is applied to the transmission sub-pixel electrode **251**, metal ions in the organic/metal hybrid polymer are oxidated into trivalent form, a highest occupied molecular orbital (HOMO) level of the metal ions is lowered and a potential gap increases. Thus, absorption area is moved to an ultraviolet region, and thus, the organic/metal hybrid polymer is recognized as colorless. The organic/metal hybrid polymer may represent various colors according to the applied voltage by changing a kind of metal ions included therein. For example, the transmission sub-pixel **25** may display red, green, blue, and white according to the application of electric signals.

**[0075]** The transmission sub-pixel **25** may use various electrochromic devices.

**[0076]** As described above, because the transmission sub-pixel **25** selectively blocks transmission of the external light according to the application of electric signals, the transmission sub-pixel **25** may further include a switching line **253** electrically coupled to the transmission sub-pixel electrode **251** as shown in FIG. 5. The switching line **253** may be located adjacent to the transmission sub-pixel **25** in order not to interfere with the external transmission through the transmission sub-pixel **25**. The switching line **253**, for example, may be disposed (or located) to cross over the first sub-pixel **21** and the third sub-pixel **23**.

**[0077]** As such, because the transmission sub-pixel **25** selectively transmits the external light (e.g., allows the external light to pass through), a first emission image  $I_1$  is displayed from the emission sub-pixels E of the organic light emitting display device and a transmission image  $I_2$  obtained from the external light transmitting through the transmission regions T is displayed as shown in FIG. 6(a), and accordingly, a user may see both the first emission image  $I_1$  and the transmission image  $I_2$ . In addition, as shown in FIG. 6(b), when the transmission sub-pixels **25** selectively block the transmission of the external light, the first emission image  $I_1$  is only displayed

from the emission sub-pixels E of the organic light emitting display device **10** so that the user may see the first emission image  $I_1$  only.

**[0078]** The transmission sub-pixels **25** may be configured to transmit external light when the electric signal is not applied thereto, and to emit light of a certain color when the electric signals are applied thereto. Here, the certain color may be one of the first through third colors, or may be a fourth color that is different from the first through third colors. To do this, the transmission adjusting layer **252** may be formed of an organic light emitting material or an electrochromic material as described above. Alternatively, in other embodiments, material transmitting external light when the electric signals are applied and emitting light of a certain color when the electric signals are not applied may be selected as the organic light emitting material.

**[0079]** In this case, the transmission sub-pixel **25** may further include a transmission driving circuit unit (or transmission driving circuit or transmission driver) **254** that is electrically coupled to the transmission sub-pixel electrode **251** as shown in FIG. 7. The transmission driving circuit unit **254** may be configured to make the transmission sub-pixel **25** function as an emission sub-pixel displaying an emission image when the external light is not transmitted through the transmission sub-pixel **25**, like the operation of first through third driving circuit units **214** through **234**. For example, in a case where the transmission sub-pixel **25** emits one of red light, green light, blue light, or white light when the external light is not transmitted through the transmission sub-pixel **25**, the transmission sub-pixel **25** may be used to represent a gray scale of the pixel P, with the first through third sub-pixels **21** through **23**. Accordingly, white balance, color, and brightness of the pixels P may be easily adjusted.

**[0080]** The transmission driving circuit unit **254** may be located in the transmission sub-pixel **25** as shown in FIG. 7; however, embodiments of the present invention are not limited thereto. That is, as shown in FIG. 8, the transmission driving circuit unit **254** may be located in one of the emission sub-pixels E adjacent to the transmission sub-pixel **25** so that the external light transmittance of the transmission sub-pixel **25** may not be degraded due to the transmission driving circuit unit **254**.

**[0081]** When the transmission sub-pixels **25** selectively transmit the external light, the first emission image  $I_1$  is displayed from the emission sub-pixels E of the organic light emitting display device **10** and the external light is transmitted through the transmission region T to display a transmission image  $I_2$  as shown in FIG. 9(a), and thus, the user may see both the first emission image  $I_1$  and the transmission image  $I_2$ . In addition, in a case where the transmission sub-pixels **25** selectively block the external light and emit light of a certain color, a second emission image  $I_3$  is displayed from the emission sub-pixel E of the organic light emitting display device **10** so that the user only sees the second emission image  $I_3$  as shown in FIG. 9(b). The second emission image  $I_3$  may have increased (or improved) white balance, color, and brightness when compared with the first emission image  $I_1$  because the transmission sub-pixel **25** functions as the emission sub-pixel representing the gray scale.

**[0082]** FIG. 10 is a plan view showing a pixel P' according to another embodiment in the organic light emission unit **2** shown in FIGS. 1 and 2.

**[0083]** The pixel P' shown in FIG. 10 may further include a fourth sub-pixel **24** in addition to the first through third sub-

pixels **21** through **23** shown in FIG. **3**. Full white light may be represented by the first through fourth sub-pixels **21** through **24** that respectively emit red light, green light, blue light, and white light. Other components may be the same as those of the previous embodiment, and thus, descriptions thereof may be omitted.

**[0084]** FIG. **11** is a plan view showing another example of a pixel P" in the organic light emission unit **2** shown in FIGS. **1** and **2**.

**[0085]** As shown in FIG. **11**, the transmission sub-pixel **25** is located adjacent to the third sub-pixel **23**.

**[0086]** In this case, if the first through third sub-pixels **21** through **23** respectively emit red light, green light, and blue light and the transmission sub-pixel **25** emits green light according to the electric signal, the pixel P" may be configured as a PenTile Matrix when the external light is not transmitted therethrough, thereby increasing (or improving) resolution of the image.

**[0087]** In the pixel P" of FIG. **11**, a fourth sub-pixel emitting white light may be further disposed (or included) in addition to the first through third sub-pixels **21** through **23** emitting red light, green light, and blue light, thereby increasing (or improving) white balance.

**[0088]** According to aspects of the present invention, the organic light emitting display device capable of selectively controlling external light transmission may be provided.

**[0089]** In addition, the white balance, the color, and the brightness of the pixels may be increased (or improved) in a non-transmission mode.

**[0090]** While the present invention has been particularly shown and described with reference to exemplary embodiments thereof, it will be understood by those of ordinary skill in the art that various changes in form and details may be made therein without departing from the spirit and scope of the present invention as defined by the following claims, and equivalents thereof.

What is claimed is:

**1.** An organic light emitting display device comprising a plurality of pixels, at least one of the pixels comprising:

- a first sub-pixel configured to emit light of a first color;
- a second sub-pixel configured to emit light of a second color that is different from the first color;
- a third sub-pixel configured to emit light of a third color that is different from the first and second colors; and
- a transmission sub-pixel configured to selectively transmit external light in response to an electrical signal.

**2.** The organic light emitting display device of claim **1**, wherein the first, second, and third sub-pixels respectively comprise a first sub-pixel electrode, a second sub-pixel electrode, and a third sub-pixel electrode that are separate from each other, and the transmission sub-pixel comprises a transmission sub-pixel electrode that is separate from the first, second, and third sub-pixel electrodes,

wherein the transmission sub-pixel electrode comprises the same material as the first, second, and third sub-pixel electrodes.

**3.** The organic light emitting display device of claim **1**, wherein the transmission sub-pixel comprises an electrochromic system.

**4.** The organic light emitting display device of claim **1**, wherein the transmission sub-pixel comprises a transmission sub-pixel electrode, a transmission opposite electrode facing the transmission sub-pixel electrode, and a transmission

adjusting layer between the transmission sub-pixel electrode and the transmission opposite electrode,

wherein the transmission sub-pixel electrode and the transmission opposite electrode comprise metal oxide, and the transmission adjusting layer comprises a transparent electrolyte.

**5.** The organic light emitting display device of claim **1**, wherein the transmission sub-pixel comprises a transmission sub-pixel electrode, a transmission opposite electrode facing the transmission sub-pixel electrode, and a transmission adjusting layer between the transmission sub-pixel electrode and the transmission opposite electrode,

wherein the transmission adjusting layer comprises an organic/metal hybrid polymer.

**6.** The organic light emitting display device of claim **1**, wherein the transmission sub-pixel is configured to transmit the external light when the electrical signal is not applied, and to emit light of one of the first, second, and third colors when the electrical signal is applied,

wherein the first, second, and third sub-pixels are located in sequence, and the transmission sub-pixel is located adjacent to the third sub-pixel,

wherein the transmission sub-pixel is configured to emit light of the second color when the electrical signal is applied.

**7.** The organic light emitting display device of claim **1**, wherein the transmission sub-pixel is configured to transmit the external light when the electrical signal is not applied, and to emit light of a fourth color that is different from the first, second, and third colors when the electrical signal is applied,

wherein the first, second, and third sub-pixels are located in sequence, and the transmission sub-pixel is located adjacent to the third sub-pixel,

wherein the transmission sub-pixel is configured to emit light of the fourth color when the electrical signal is applied.

**8.** The organic light emitting display device of claim **1**, wherein the at least one of the pixels further comprises a fourth sub-pixel that is configured to emit light of a fourth color that is different from the first, second, and third colors.

**9.** The organic light emitting display device of claim **8**, wherein the transmission sub-pixel is located adjacent to the first, second, third and fourth sub-pixels.

**10.** An organic light emitting display device comprising a plurality of pixels, at least one of the pixels comprising:

an emission sub-pixel configured to display an emission image; and

a transmission sub-pixel configured to selectively display a transmission image by external light transmitted through the transmission sub-pixel.

**11.** The organic light emitting display device of claim **10**, wherein the emission sub-pixel comprises an emission sub-pixel electrode, and the transmission sub-pixel comprises a transmission sub-pixel electrode,

wherein the transmission sub-pixel electrode comprises the same material as the emission sub-pixel electrode.

**12.** The organic light emitting display device of claim **10**, wherein the transmission sub-pixel comprises an electrochromic system.

**13.** The organic light emitting display device of claim **10**, wherein the transmission sub-pixel comprises a transmission sub-pixel electrode, a transmission opposite electrode facing the transmission sub-pixel electrode, and a transmission

adjusting layer between the transmission sub-pixel electrode and the transmission opposite electrode,

wherein the transmission sub-pixel electrode and the transmission opposite electrode comprise metal oxide, and the transmission adjusting layer comprises a transparent electrolyte.

**14.** The organic light emitting display device of claim **10**, wherein the transmission sub-pixel comprises a transmission sub-pixel electrode, a transmission opposite electrode facing the transmission sub-pixel electrode, and a transmission adjusting layer between the transmission sub-pixel electrode and the transmission opposite electrode,

wherein the transmission adjusting layer comprises an organic/metal hybrid polymer.

\* \* \* \* \*

专利名称(译)	有机发光显示装置		
公开(公告)号	<a href="#">US20150379925A1</a>	公开(公告)日	2015-12-31
申请号	US14/849447	申请日	2015-09-09
[标]申请(专利权)人(译)	三星显示有限公司		
申请(专利权)人(译)	三星DISPLAY CO. , LTD.		
当前申请(专利权)人(译)	三星DISPLAY CO. , LTD.		
[标]发明人	JUNG CHAN SUNG CHOI JAE WON JUNG TAE HYEOG		
发明人	JUNG, CHAN-SUNG CHOI, JAE-WON JUNG, TAE-HYEOG		
IPC分类号	G09G3/32		
CPC分类号	G09G5/02 G09G3/32 H01L27/3232 H01L27/326 G09G3/3208 G09G2300/046 H01L27/3206 H01L27/3213 H01L27/3248		
优先权	1020130014972 2013-02-12 KR		
其他公开文献	US9721497		
外部链接	<a href="#">Espacenet</a> <a href="#">USPTO</a>		

摘要(译)

一种有机发光显示装置，包括多个像素，所述多个像素中的每一个包括：第一子像素，被配置为发射第一颜色的光；第二子像素，被配置为发出与第一颜色不同的第二颜色的光；第三子像素，用于发出与第一颜色和第二颜色不同的第三颜色的光；发送子像素，被配置为响应于电信号选择性地发送外部光。

